

**Building on the success of the innovative TIDD PC28 Pick and Carry Crane, with its class leading capacity, safety, and comfort, TRT is pleased to announce new upgrades.**

Leading from the front, TRT continues to enhance the overall TIDD Crane operator experience. The upgrades to the newly named **TIDD PC28-2**, are driven through TRT's focus on continuous improvement, with consideration of industry and operator feedback.

## WHAT'S NEW TO TIDD PC28-2

### Greater Lift Capacity

TRT's TIDD PC28-2 has more powerful front suspension cylinders, achieving greater lift capacity when articulated and working on a side slope, **increasing the load chart by up to 17%.**

### Improved Lift Control

With an additional three steps on the TIDD PC28-2 load chart, there is a significant improvement to the articulation. As the crane articulates, **this reduces the rate of the load chart decrease.**

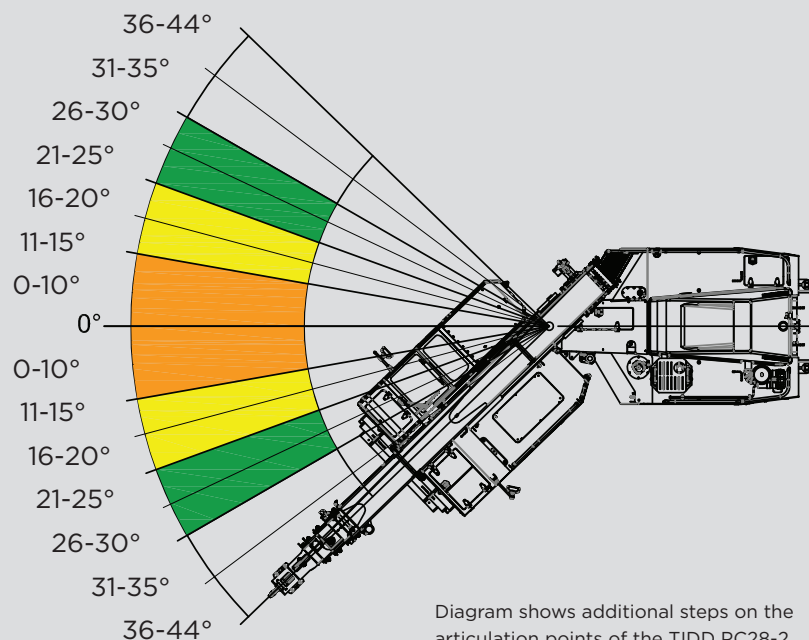

### Improved Software Response

The Robway® TIDD Crane operating software has been upgraded with improved function. This enables faster processing and **greater control responsiveness** for the TIDD PC28-2 operator.

### Improved Operator Comfort

With operator and dogman comfort central to the design of the TIDD Crane, TRT has re-engineered the ROPS cabin, lowering ambient noise on the road. Cabin noise levels are reduced by **8dBa at 80km/hr.**