

SPECIFICATIONS SUBJECT TO
CHANGE WITHOUT NOTICE

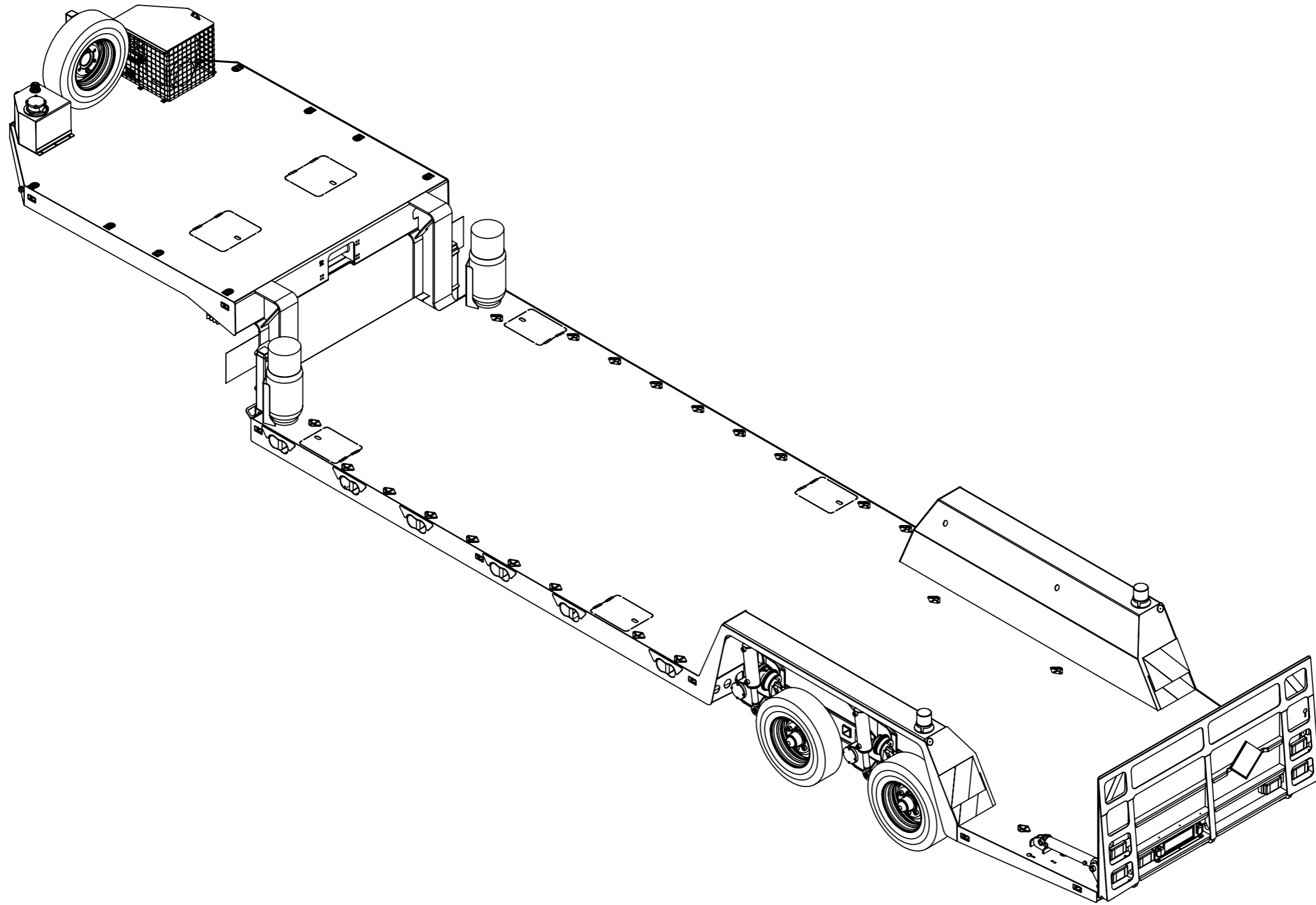

TOLERANCE : ± 0.5mm UNLESS OTHERWISE STATED
WIRE BUFF ALL STEEL COMPONENTS PRIOR TO WELDING
WELDING: ALL INFORMATION SHALL COMPLY WITH NZ/AS 1554:2000 PT 1 CATEGORY SP UNLESS OTHERWISE STATED AND SHALL BE WELDED TO A QUALIFIED PROCEDURE, BY A WELDER QUALIFIED FOR THE APPROPRIATE POSITION AND SUPERVISED BY A WELDING SUPERVISOR
 THIS DRAWING IS © COPYRIGHT AND IS THE PROPERTY OF TIDD ROSS TODD LTD. IT IS FURNISHED TO YOU FOR CONFIDENTIAL INFORMATION PURPOSES ONLY AND IS NOT TO BE DISCLOSED TO ANYONE ELSE OR USED FOR MANUFACTURING PURPOSES WITHOUT THE EXPRESS WRITTEN PERMISSION OF TIDD ROSS TODD LTD.

REV	DATE	COMMENT	NAME

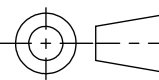

TIDD ROSS TODD LIMITED

48 Maui Street
 Hamilton
 New Zealand
 Phone +64 7 849 4839
 Fax +64 7 849 3628
 Email : trt@trt.co.nz
 ISO 9001

	NAME	DATE
DRAWN	DT	19/04/2018
CHK'D	-	-
APPV'D	-	-

TITLE:		REVISION	
TANDEM FORKLIFT TRAILER		A	
SHEET 1 OF 2	DWG NO.	259-A01W	
DO NOT SCALE DRAWINGS IN mm's	STATUS - M	SCALE:1:35	

SPECIFICATIONS SUBJECT TO
CHANGE WITHOUT NOTICE

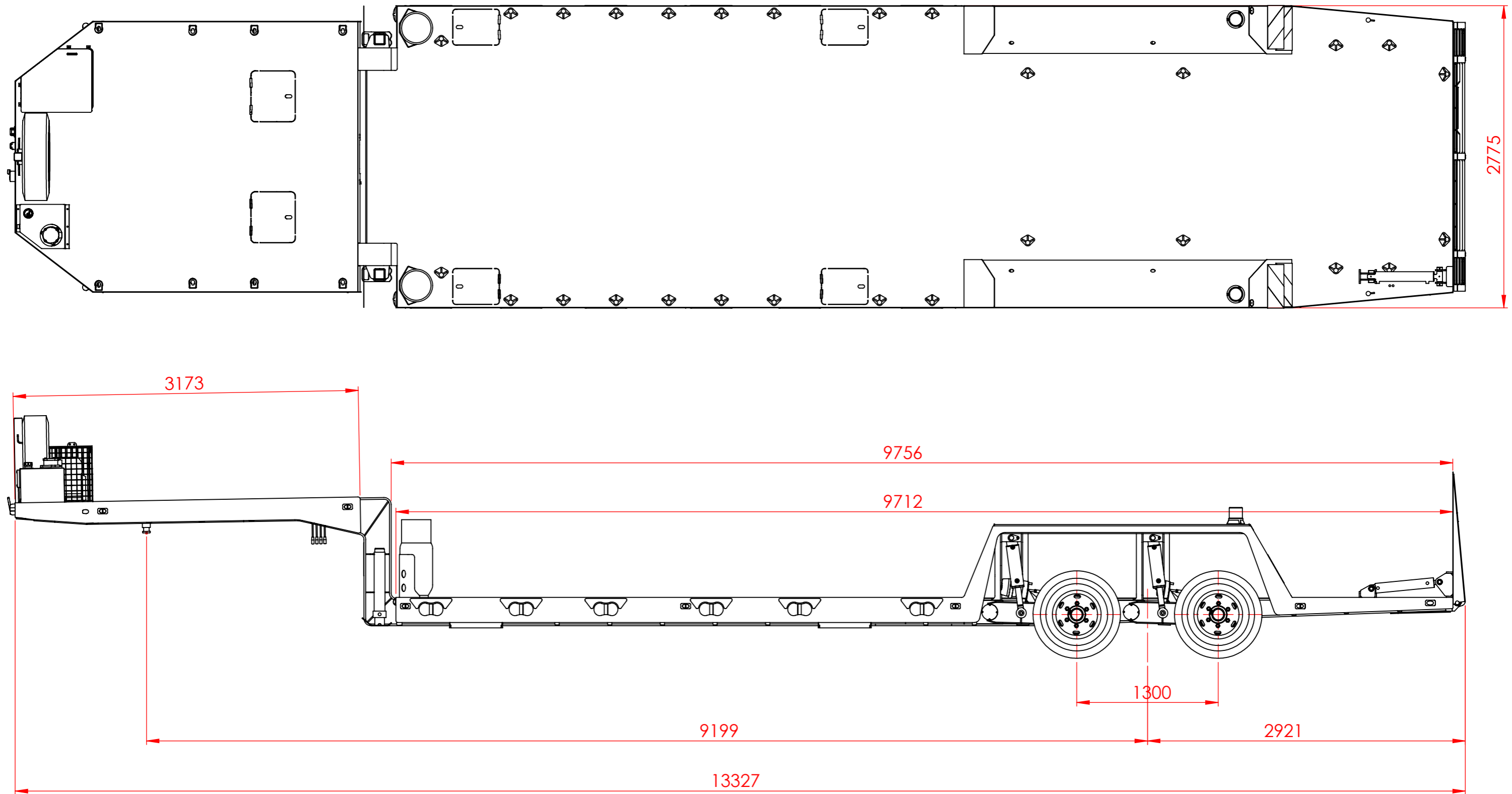

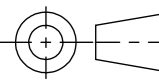
TOLERANCE : ± 0.5mm UNLESS OTHERWISE STATED
WIRE BUFF ALL STEEL COMPONENTS PRIOR TO WELDING
WELDING: ALL INFORMATION SHALL COMPLY WITH NZ/AS 1554:2000 PT 1 CATEGORY SP UNLESS OTHERWISE STATED AND SHALL BE WELDED TO A QUALIFIED PROCEDURE, BY A WELDER QUALIFIED FOR THE APPROPRIATE POSITION AND SUPERVISED BY A WELDING SUPERVISOR
 THIS DRAWING IS © COPYRIGHT AND IS THE PROPERTY OF TIDD ROSS TODD LTD. IT IS FURNISHED TO YOU FOR CONFIDENTIAL INFORMATION PURPOSES ONLY AND IS NOT TO BE DISCLOSED TO ANYONE ELSE OR USED FOR MANUFACTURING PURPOSES WITHOUT THE EXPRESS WRITTEN PERMISSION OF TIDD ROSS TODD LTD.

REV	DATE	COMMENT	NAME



48 Maui Street
 Hamilton
 New Zealand
 Phone +64 7 849 4839
 Fax +64 7 849 3628
 Email : trt@trt.co.nz
 ISO 9001

	NAME	DATE
DRAWN	DT	19/04/2018
CHK'D	-	-
APPV'D	-	-

TITLE:		REVISION	
TANDEM FORKLIFT TRAILER		A	
SHEET 2 OF 2	DWG NO.	259-A01W	
DO NOT SCALE DRAWINGS IN mm's	STATUS - M	SCALE:1:35	