

TRT

MADE
POSSIBLE

AXLE WIDENING LOW LOADER



Open centre allows dipper arm to lower below deck

- 2.5m Closed - 3.5m Open
- Hi Tensile Construction, AR450 Deck Sheet strong and light
- Air or Hydraulic Suspension
- Independent Axle Lift
- Deep Coaming Rail and full depth chassis
- Single or Bi-Fold Ramps
- BPW Steering Axles widen with decks
- Widening stool lifts all wheels, protects new Bitumen
- Sliding Skid Plate



TRT

**MADE
POSSIBLE**



STEERING AXLE

- Widens with deck, increased stability
- Alignment maintained
- Increased manoeuvrability, less tyre wear, fuel consumption & reduced chassis stress



DOUBLE ACTING HYDRAULIC SUSPENSION

- Increased stability over single acting design
- Lift any axle, no mechanical pinning required
- No jacks required when servicing or tyre change



WIDENING STOOL

- Deploys at the touch of a lever
- Lift all wheels off ground when widening
- Reduce tyre wear
- No damage to Bitumen surface

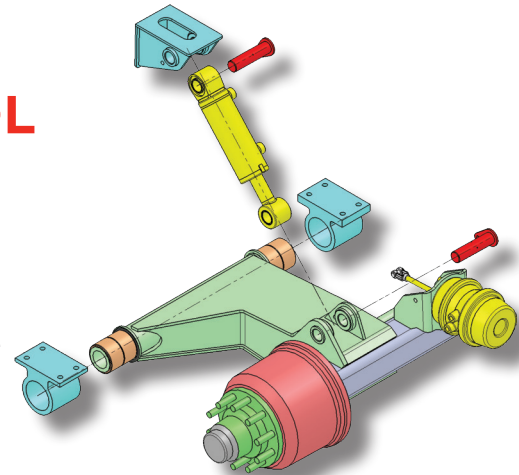

2x4 DOLLY

- Hi tensile construction for lowest tare weight from 3170kg, maximises payload
- Unique chassis design provides maximum axle weight split



OPTIONS

- Air or Hydraulic Suspension
- Steering Axles
- Single or Bi-fold Ramps
- Petrol or Diesel Power Pack
- Widening Stool
- Auto Grease System
- Conveyor Belt Deck Covering
- Accumulators
- Stainless Steel Protectors (load restraints)
- Hydraulic Winch

25032022

TRT
DESIGNED &
MANUFACTURED

TRT Australia
Phone: +61 7 3890 8800
Email: trailers@trtaust.com.au
www.trtaustralia.com.au

TRT New Zealand
Phone: +64 7 849 4839
Email: trailers@trt.co.nz
www.trt.co.nz