

IF IN DOUBT PLEASE ASK

5086 - FLOOR LENGTH

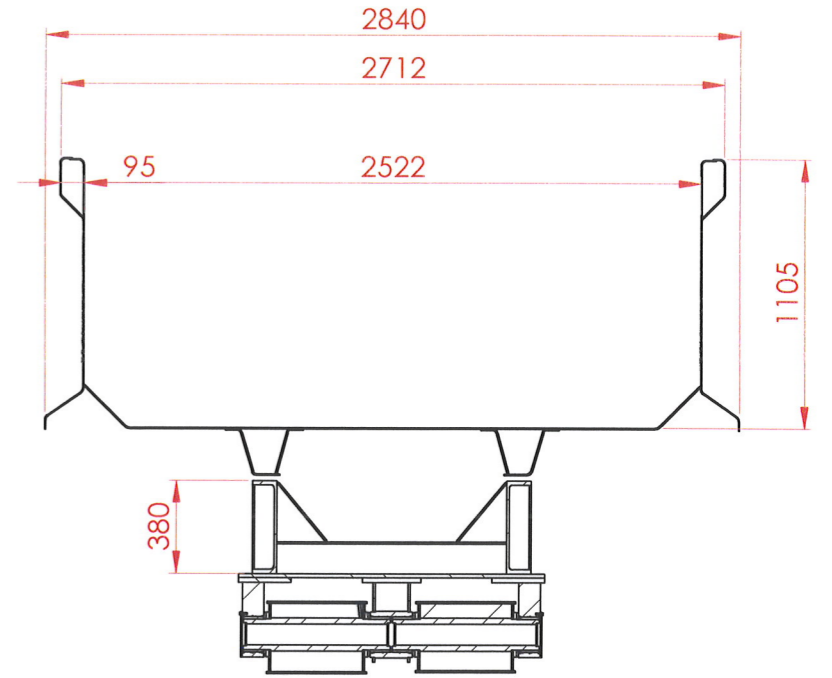

SECTION A-A

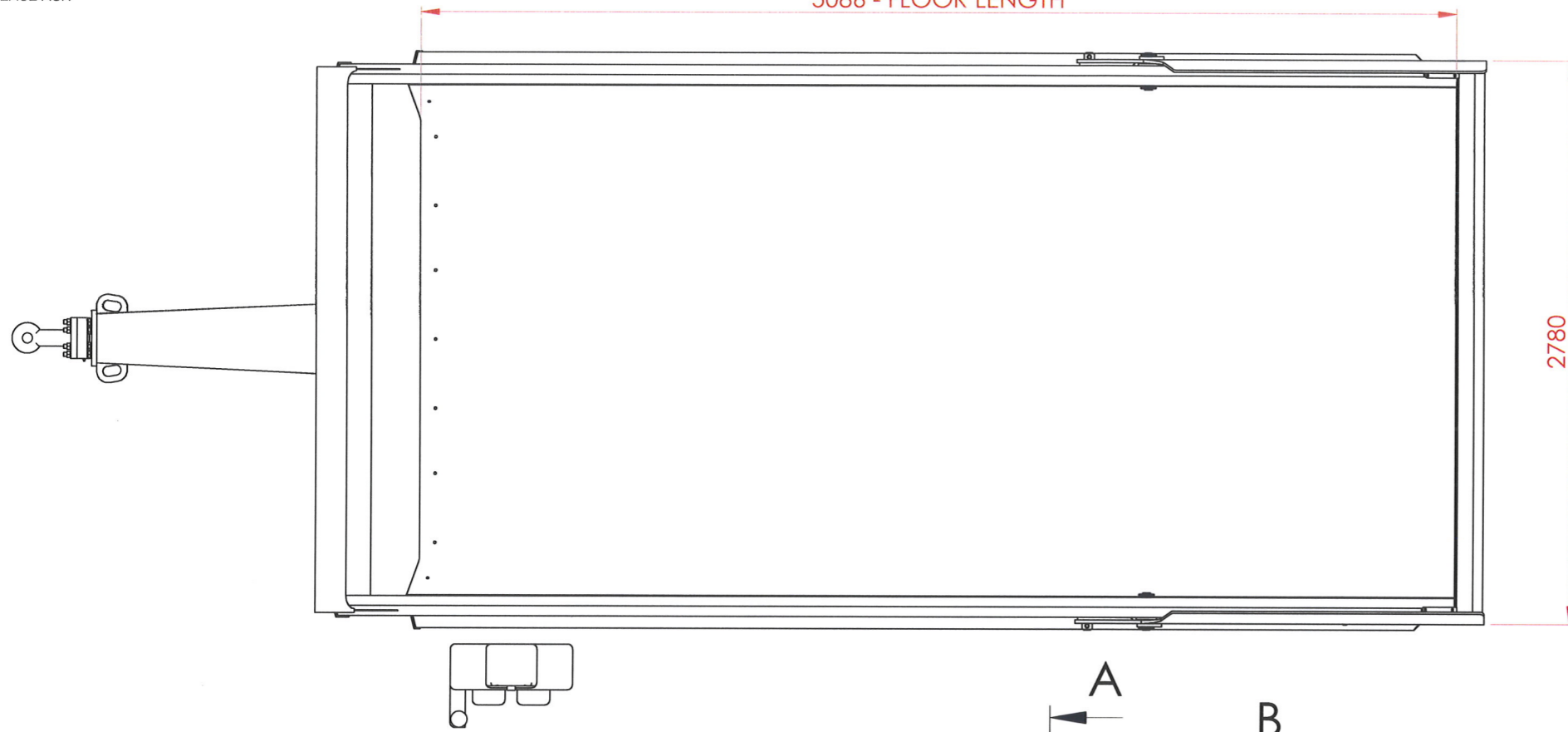
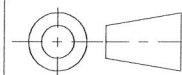
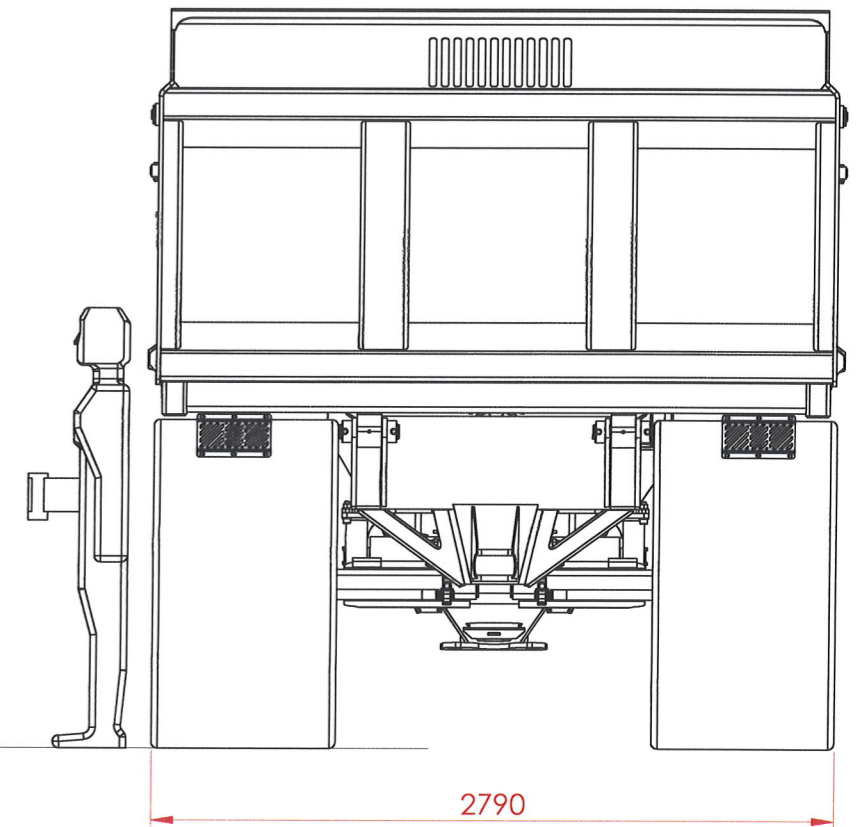
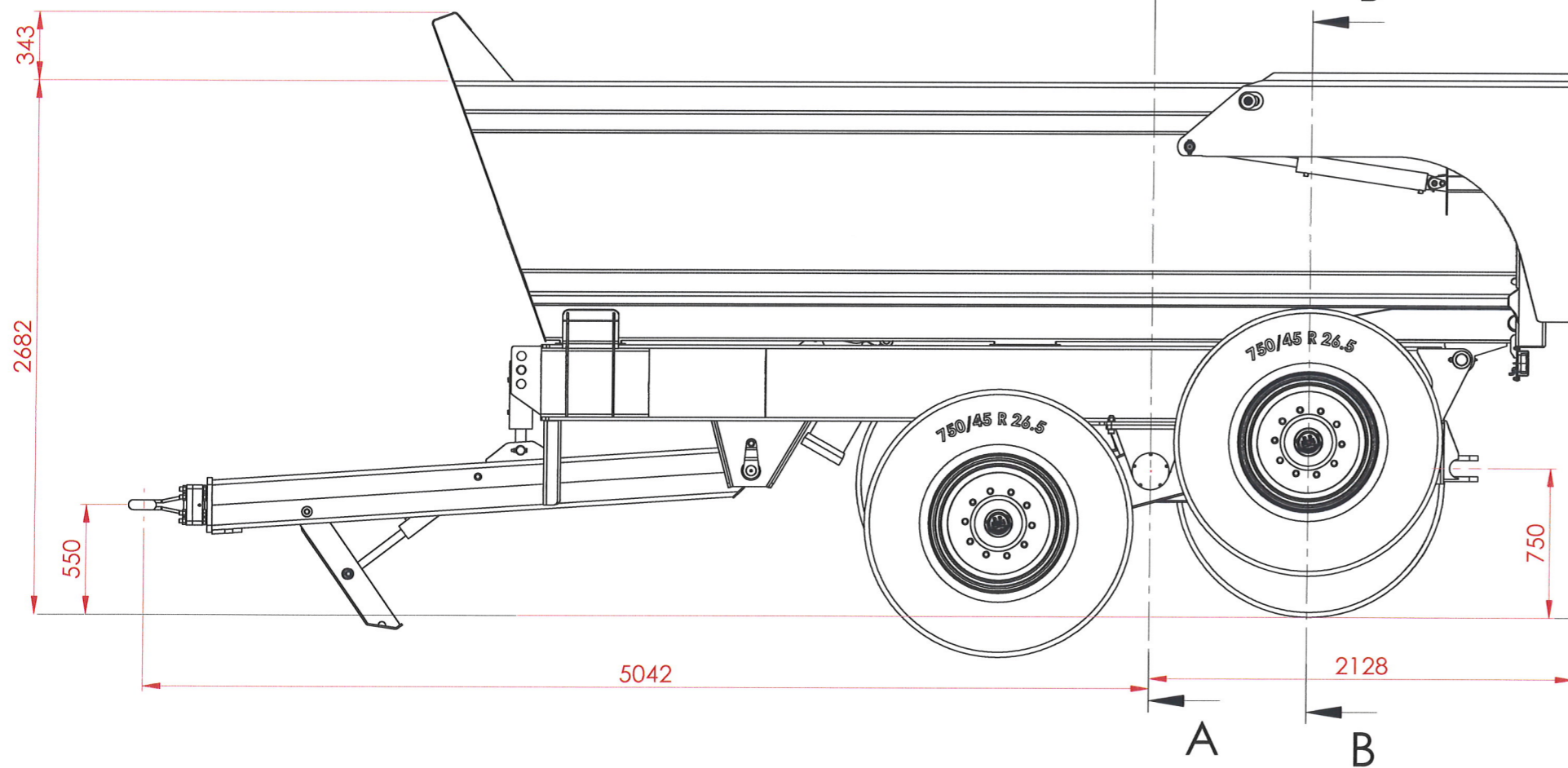

TOLERANCE : : 0.5mm UNLESS OTHERWISE STATED
WIRE BUFF ALL STEEL COMPONENTS PRIOR TO WELDING

WELDING: ALL INFORMATION SHALL COMPLY WITH NZ/AS 1554:2000 PT 1 CATEGORY SP UNLESS OTHERWISE STATED AND SHALL BE WELDED TO A QUALIFIED PROCEDURE, BY A WELDER QUALIFIED FOR THE APPROPRIATE POSITION AND SUPERVISED BY A WELDING SUPERVISOR

THIS DRAWING IS © COPYRIGHT AND IS THE PROPERTY OF TIDD ROSS TODD LTD. IT IS FURNISHED TO YOU FOR CONFIDENTIAL INFORMATION PURPOSES ONLY AND IS NOT TO BE DISCLOSED TO ANYONE ELSE OR USED FOR MANUFACTURING PURPOSES WITHOUT THE EXPRESS WRITTEN PERMISSION OF TIDD ROSS TODD LTD.

REV	DATE	COMMENT



48 Maui Street
Hamilton, New Zealand
Telephone +64 7 849 4839
Fax +64 7 849 3628
Email : trt@trt.co.nz
ISO 9001

NAME	DATE	TITLE:	REVISION
DRAWN	RJC	04/08/2016	FULL ASSY
CHK'D	-	-	-
APPV'D	-	-	-
DO NOT SCALE DRAWINGS IN mm's		STATUS - M	SCALE:1:30
SHEET 1 OF 4		DWG NO.	REVISION
262-200-C1		A	

IF IN DOUBT PLEASE ASK

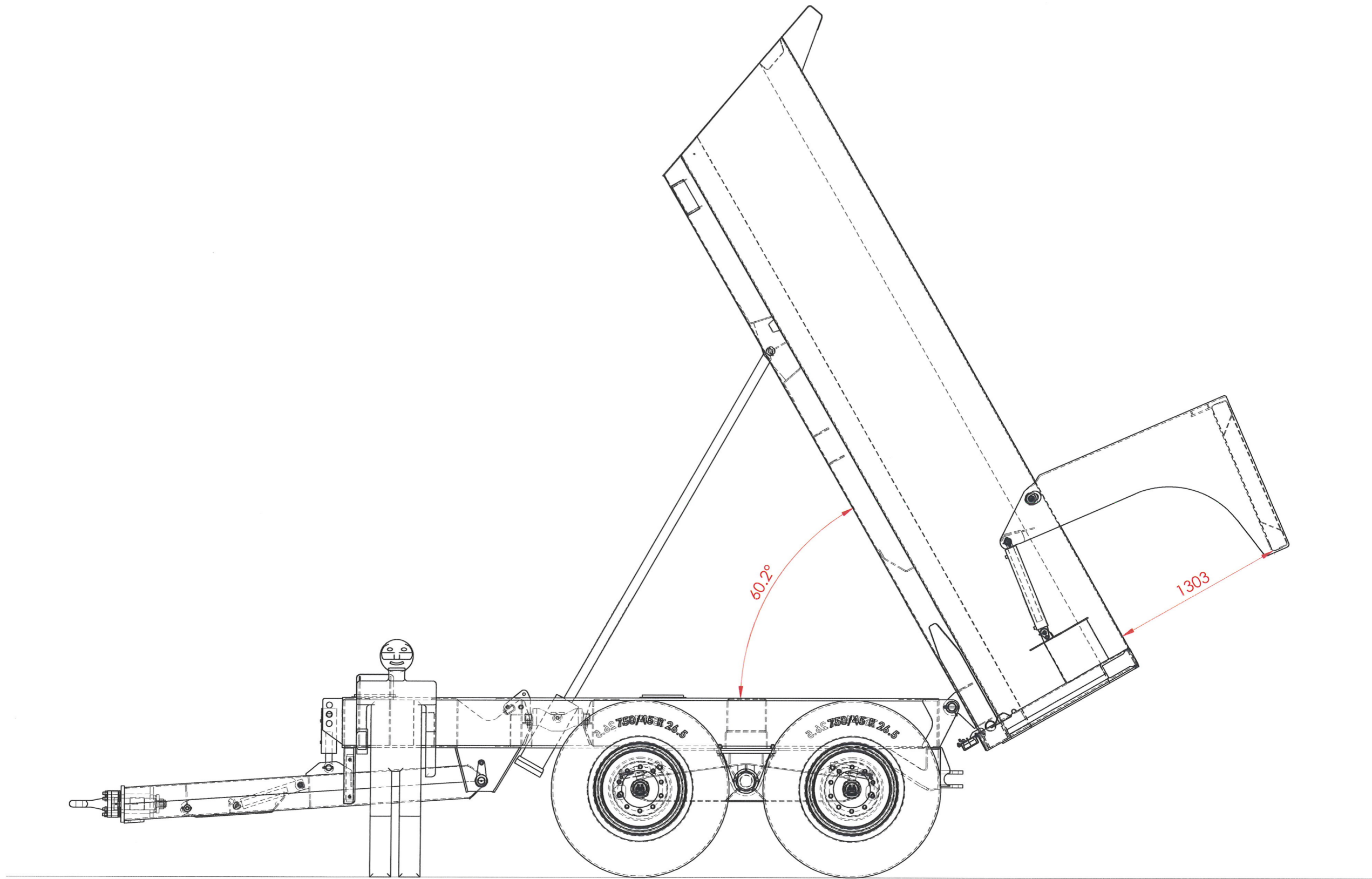

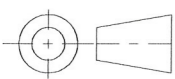
TOLERANCE : ± 0.5mm UNLESS OTHERWISE STATED
WIRE BUFF ALL STEEL COMPONENTS PRIOR TO WELDING
 THIS DRAWING IS © COPYRIGHT AND IS THE PROPERTY OF TIDD ROSS TODD LTD. IT IS FURNISHED TO YOU FOR CONFIDENTIAL INFORMATION PURPOSES ONLY AND IS NOT TO BE DISCLOSED TO ANYONE ELSE OR USED FOR MANUFACTURING PURPOSES WITHOUT THE EXPRESS WRITTEN PERMISSION OF TIDD ROSS TODD LTD.

WELDING: ALL INFORMATION SHALL COMPLY WITH NZ/AS 1554:2000 PT 1 CATEGORY SP UNLESS OTHERWISE STATED AND SHALL BE WELDED TO A QUALIFIED PROCEDURE, BY A WELDER QUALIFIED FOR THE APPROPRIATE POSITION AND SUPERVISED BY A WELDING SUPERVISOR

REV	DATE	COMMENT



48 Maui Street
 Hamilton, New Zealand
 Telephone +64 7 849 4839
 Fax +64 7 849 3628
 Email : trt@trt.co.nz
 ISO 9001

NAME	DATE	TITLE:	REVISION
DRAWN	RJC	04/08/2016	FULL ASSY ~ RAISED
CHK'D	-	-	SHEET 2 OF 4
APP'VD	-	-	DWG NO. 262-200-C1
DO NOT SCALE DRAWINGS IN mm's		STATUS - M	SCALE:1:30

IF IN DOUBT PLEASE ASK

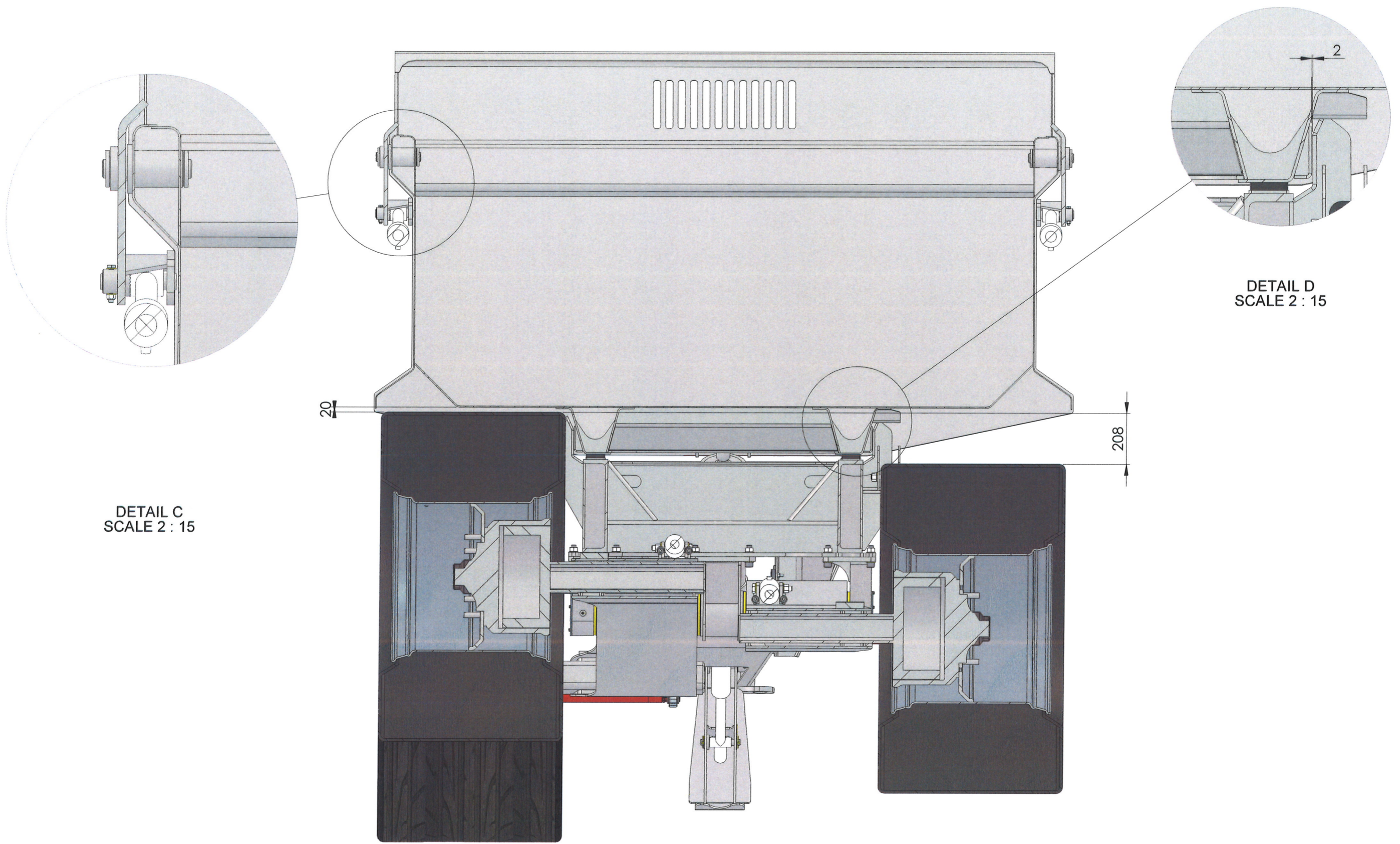

DETAIL C
SCALE 2 : 15

DETAIL D
SCALE 2 : 15

AXLE RAISED

SECTION B-B

AXLE LEVEL

 TOLERANCE : ± 0.5mm UNLESS OTHERWISE STATED
WIRE BUFF ALL STEEL COMPONENTS PRIOR TO WELDING

WELDING: ALL INFORMATION SHALL COMPLY WITH NZ/AS 1554:2000 PT 1 CATEGORY SP UNLESS OTHERWISE STATED AND SHALL BE WELDED TO A QUALIFIED PROCEDURE, BY A WELDER QUALIFIED FOR THE APPROPRIATE POSITION AND SUPERVISED BY A WELDING SUPERVISOR

THIS DRAWING IS © COPYRIGHT AND IS THE PROPERTY OF TIDD ROSS TODD LTD.
IT IS FURNISHED TO YOU FOR CONFIDENTIAL INFORMATION PURPOSES ONLY AND IS NOT TO BE DISCLOSED TO ANYONE ELSE OR USED FOR MANUFACTURING PURPOSES WITHOUT THE EXPRESS WRITTEN PERMISSION OF TIDD ROSS TODD LTD.

REV	DATE	COMMENT



48 Maui Street
Hamilton, New Zealand
Telephone +64 7 849 4839
Fax +64 7 849 3628
Email : trt@trt.co.nz
ISO 9001

NAME	DATE	TITLE:	DWG NO.	REVISION
DRAWN RJC	04/08/2016	FULL ASSY ~ SECTION	262-200-C1	A
CHK'D -	-	SHEET 3 OF 4		
APP'VD -	-	SCALE:1:15		
DO NOT SCALE DRAWINGS IN mm's		STATUS - M		

IF IN DOUBT PLEASE ASK

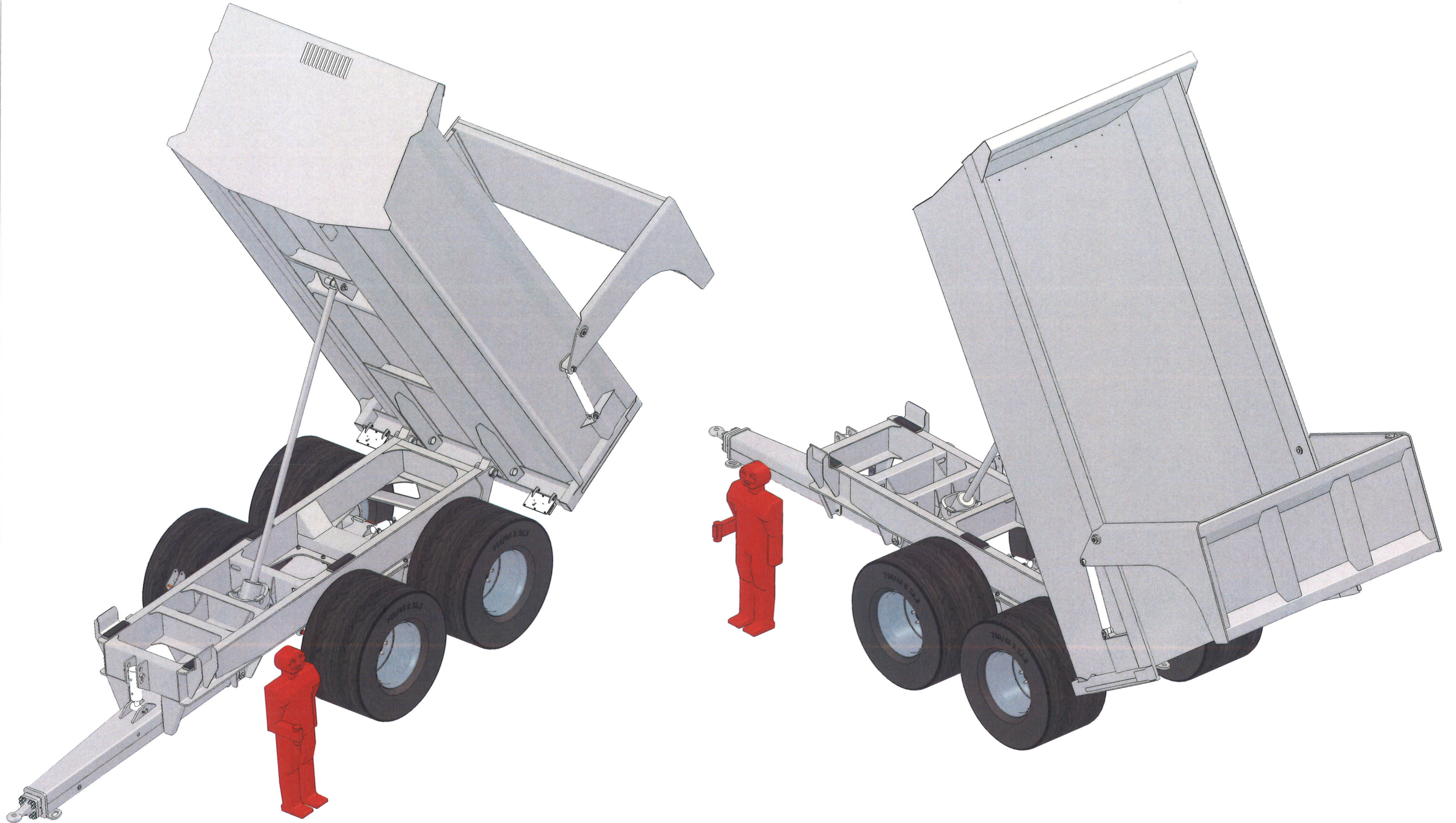

TOLERANCE : ± 0.5mm UNLESS OTHERWISE STATED
 WIRE BUFF ALL STEEL COMPONENTS PRIOR TO WELDING
WELDING: ALL INFORMATION SHALL COMPLY WITH NZ/AS 1554:2000 PT 1 CATEGORY SP UNLESS OTHERWISE STATED AND SHALL BE WELDED TO A QUALIFIED PROCEDURE, BY A WELDER QUALIFIED FOR THE APPROPRIATE POSITION AND SUPERVISED BY A WELDING SUPERVISOR

REV	DATE	COMMENT



48 Maui Street
 Hamilton, New Zealand
 Telephone +64 7 849 4839
 Fax +64 7 849 3628
 Email : trt@trt.co.nz
 ISO 9001

NAME	DATE	TITLE:	DWG NO.	REVISION
DRAWN RJC	04/08/2016	FULL ASSY ~ RAISED	262-200-C1	A
CHK'D -	-	SHEET 4 OF 4		
APPV'D -	-	SCALE:1:35		
DO NOT SCALE DRAWINGS IN mm's		STATUS - M		